

HÜBNER BERLIN

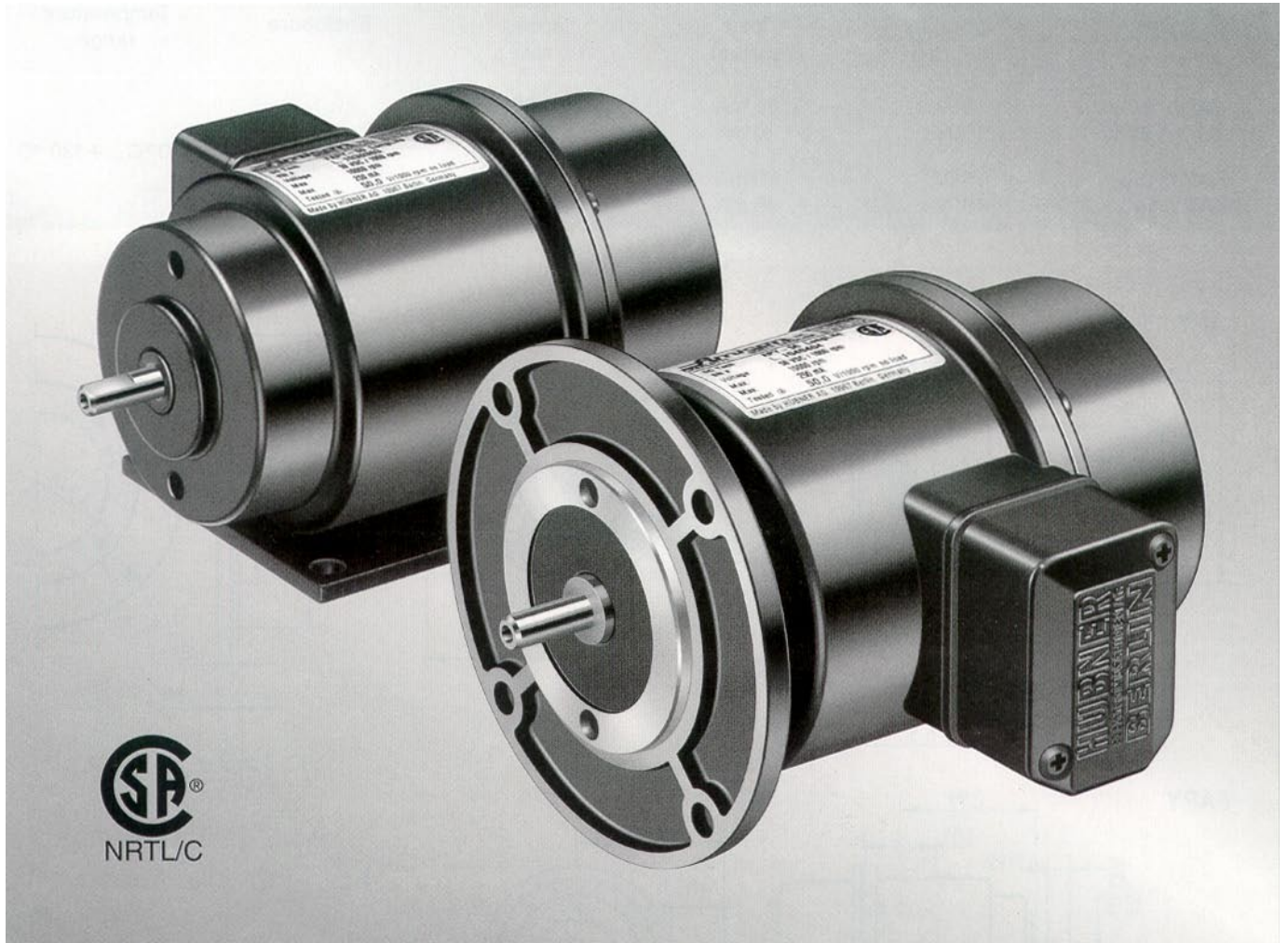

APY • FAPY
LongLife DC Tachometers



APY • FAPY TACHOMETERS

LongLife DC Tachometers in industrial NEMA 12 housings are available with flange or foot mount for direct replacement of "PY" or "BC" style tachometers. These tachometers are CSA / NRTL / C approved. 50 or 100 V DC / krpm outputs are available with regulation of 1 % or .1 % for precise speed control in all applications.

HÜBNER, Europe's leading technological manufacturer of tachometers, presents the LongLife Technology, resulting in the best tachometers available in the world. A patented design and process imbeds a silver track in the commutator. The result is high precision output, low ripple and a brush/commutator life that exceeds that of the precision ball-bearings (10^9 revolutions).

Type	No-load voltage 1000 rpm	Max. load current	Max. speed rpm	Enclosure	Temperature range
APY 50	50 V	80 mA	10000	IP 55	-30 °C ... +130 °C
APY 100	100 V	40 mA	6000		
FAPY 50	50 V	80 mA	10000		
FAPY 100	100 V	40 mA	6000		

